

# BC 350

Tende a bracci su staffe indipendenti  
Tragrohrlose Markisen  
Stores à bras en étriers indépendants

---

## IT

BC 350: Tenda a bracci su staffe indipendenti con supporto braccio laterale fisso.  
Sporgenza massima 350 cm.

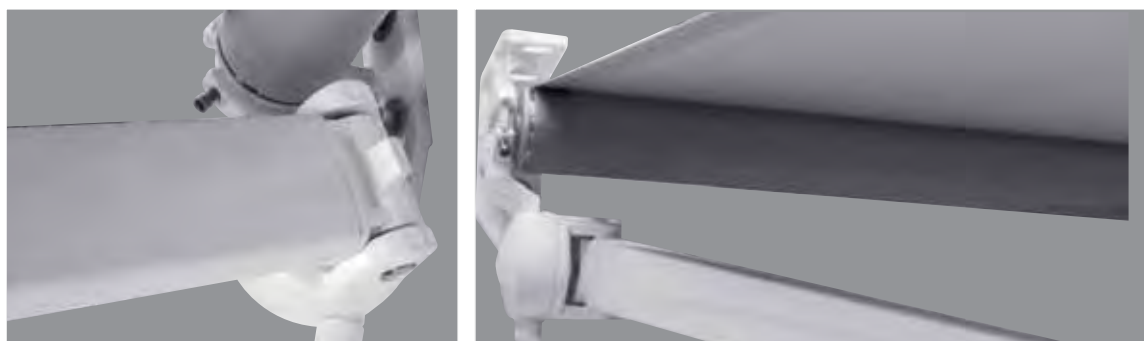

---

## DE

BC 350: Gelenkarm Markise mit seitlicher Armkonsole.  
Maximal Ausladung 350 cm.

---

## FR

BC 350: Store à bras sur étriers indépendants avec support bras latéral fixe.  
Dimensions maximums: avancée 350 cm.

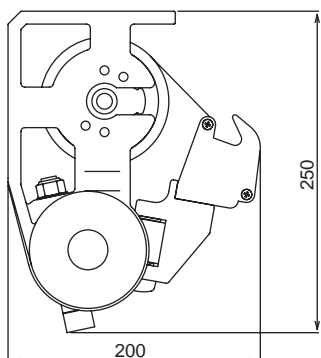
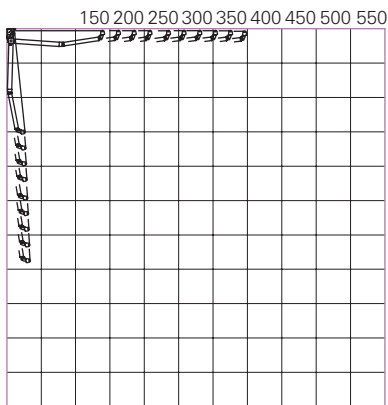
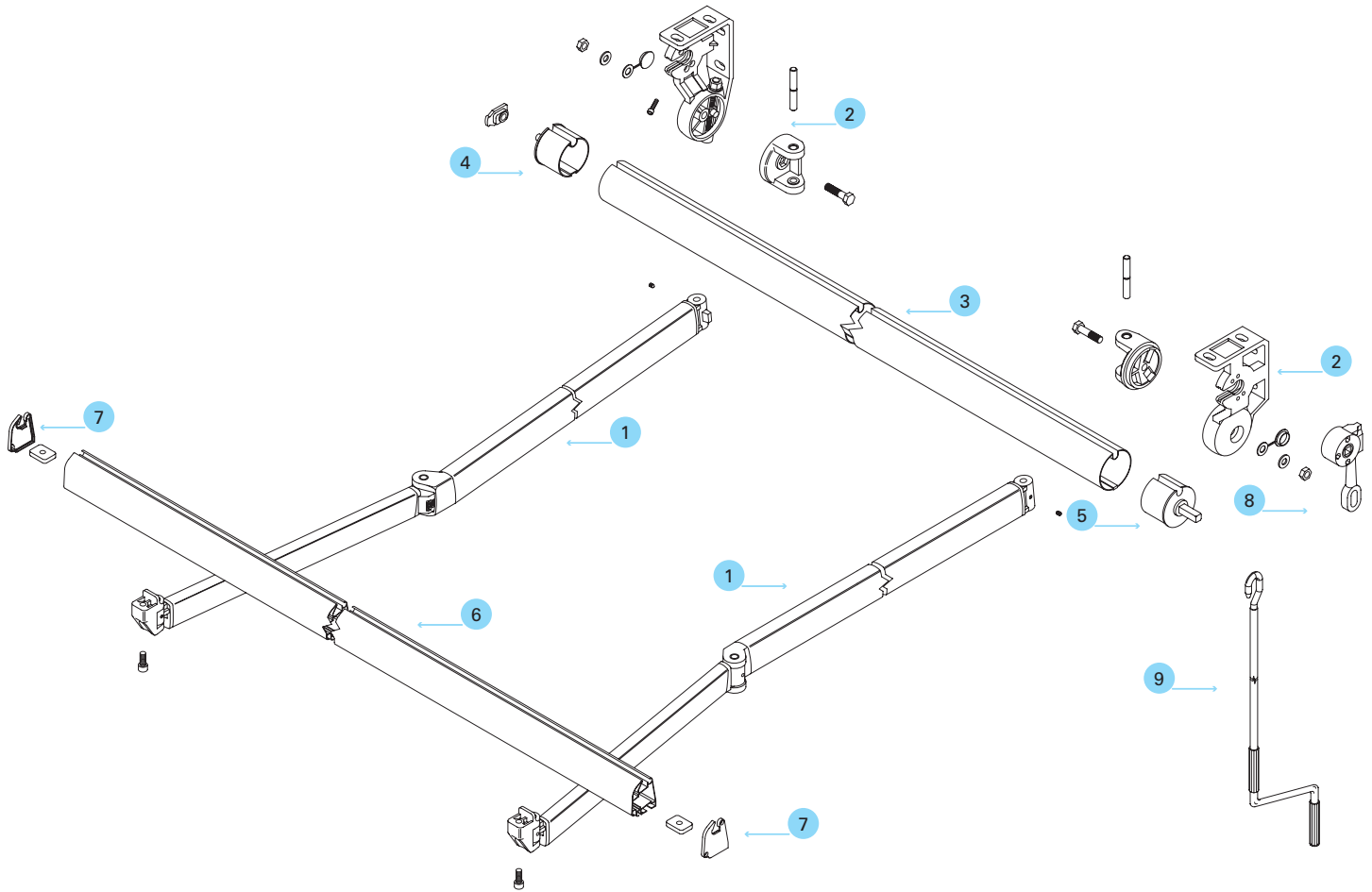

**BC 350**

- 1 braccio - Gelenkarm - bras
- 2 staffa con disco - Träger mit Platte - support avec disque
- 3 tubo avvolgitore - Tuchwelle - tube enrouleur
- 4 calotta in nylon perno tondo - Wellenkapsel nylon mit Rundstift - calotte en nylon pivot rond
- 5 calotta in nylon perno quadro - Wellenkapsel nylon mit Vierkantstift - calotte en nylon pivot carré
- 6 terminale pesante lux - Schwere Fallstange Lux - barre de charge lourde lux
- 7 tappo pvc terminale lux - PVC Deckel für schwere Fallstange Lux - bouchon pvc barre de charge lux
- 8 arganello - Getriebe - treuil
- 9 asta manovra - Kurbelstab - manivelle



# BQ 400

Tenda a bracci su barra quadra  
Tragrohr Markise  
Store à bras en barre carrée

IT

BQ 400: tenda a bracci su barra quadra 40x40 mm con supporto braccio a posizionamento laterale e intermedio. Sporgenza massima 400 cm.

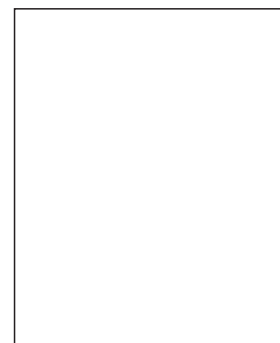

DE

BQ 400: Gelenkarm Markise mit 40x40 mm Tragrohr mit seitlicher oder zwischen Armkonsolen. Maximal Ausladung 400 cm.

FR

BQ 400: store à bras sur barre carrée 40x40 mm avec support bras à positionnement latéral et intermédiaire. Dimensions maximums: avancée 400 cm.

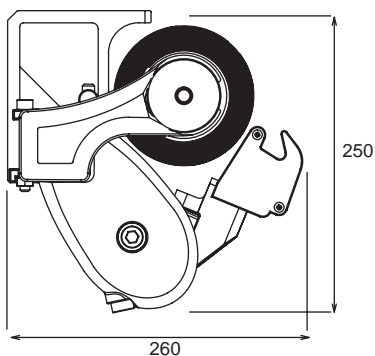
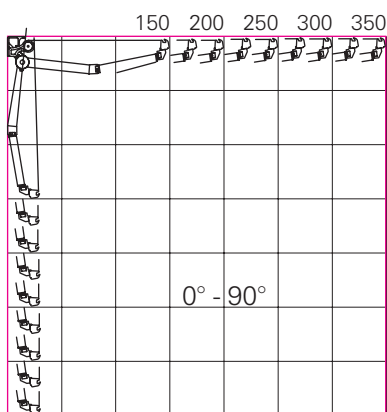
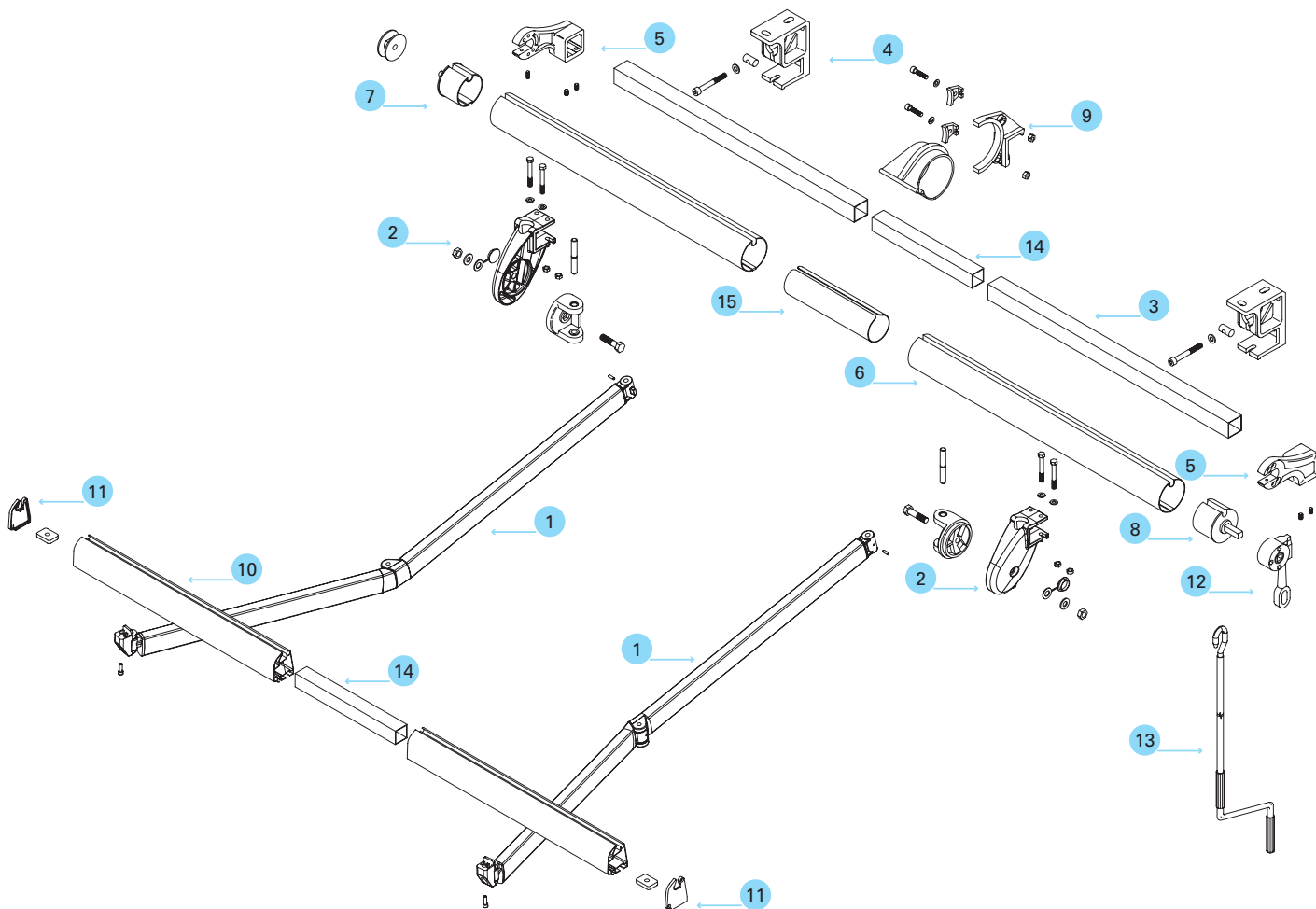

**BQ 400**

- 1 braccio - Gelenkarm - bras
- 2 supporto braccio con disco - Armkonsole mit Platte - support bras avec disque
- 3 barra quadra - Tragrohr - barre carrée
- 4 staffa universale - Universal Konsole - étrier de fixation universel
- 5 supporto tubo avvolgitore - Tuchwellenlager - support tube enrouleur
- 6 tubo avvolgitore - Tuchwelle - tube enrouleur
- 7 calotta in nylon perno tondo - Wellenkapsel nylon mit Rundstift - calotte en nylon pivot rond
- 8 calotta in nylon perno quadro - Wellenkapsel nylon mit Vierkantstift - calotte en nylon pivot carré
- 9 supporto compensatore in nylon - Stuetzlager PVC - support compensateur en nylon
- 10 terminale pesante lux - Schwere Fallstange Lux - barre de charge lourde lux
- 11 tappo pvc terminale lux - PVC Deckel für schwere Fallstange Lux - bouchon pvc barre de charge lux
- 12 arganello - Getriebe - treuil
- 13 asta manovra - Kurbelstab - manivelle
- 14 giunzione per barra quadra e terminali - Fallstangen und Tragrohr Kupplung - jonction diam pour barre carrée et barres de charge
- 15 giunzione per tubo avvolgitore - Tuchwellen Kupplung - jonction support tube enrouleur